

# MASTER-LINE

# Modell SC-15-500.D10

## Schraubenkompressoren

## Screwcompressors

Technische Daten / Technical specifications	Motor	kW HP	15 20,40		
	Lieferleistung FAD	l/min. CFM	2.150 75,92	1.900 67,09	1.400 49,44
	Max. Druck Max. pressure	bar psi	8 120	10 145	15 217
	Behältervolumen Tank size	liter/litres gallon	500 132,09		
	Gewicht Weight	kg lbs	520 1.146,5		
	Schallemissionen Noise level	dB(A)/1m	77		
	Luftanschluss Air connection	G	¾"		
	Abmessungen (L x B x H) Dimensions (l x w x h)	mm inch	890 x 680 x 1025 80,0 x 26,8 x 62,5		

Ausstattung / Equipment	Schallschutzgehäuse Acoustic housing	x
	Druckbehälter Pressure vessel	x
	Kondensatablass mit Kugelhahn Condensate drain ball valve	x
	Programmierbare Steuereinheit Programmable controller	P1
	LED-Display	x
	Not-Aus-Schalter Emergency shut-down switch	x
	Stern-Dreieck-Anlauf Star / Delta Start-up	x
	Zusätzliche Kesseldruckmanometer Additional pressure vessel gauge	x
	Temperaturüberwachung Temperature monitoring/control	x
	Mindestdruckventil Minimum pressure valve	x
	Elektromagnetischer Ansaugregler Electromagnetic intake regulator	x
	Ölvorabscheidung Oil pre-separation	x
	Ölseparator Oil separator	x
	Ölfilter Oil filter	x
	Großflächiger Wabenkühler Large area honeycomb cooler	x

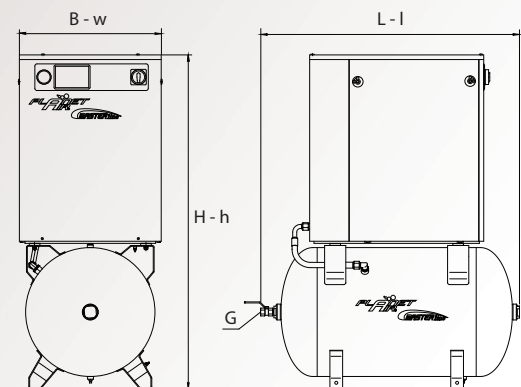

Technische Änderungen vorbehalten. / Technical changes reserved.



PLANET-AIR GmbH  
Kornkamp 16  
22926 Ahrensburg  
Germany

Tel.: +49 (0)4102 4953-0  
Fax: +49 (0)4102 4953-45  
E-Mail: info@planet-air.de  
www.planet-air.de

Photo: © momezzo - Fotolia.com